

8C BCH  
G7 5@: FCA  
Hk GDF BH

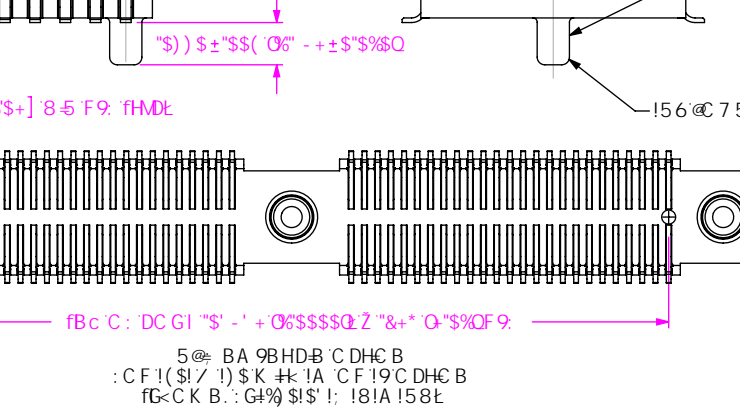
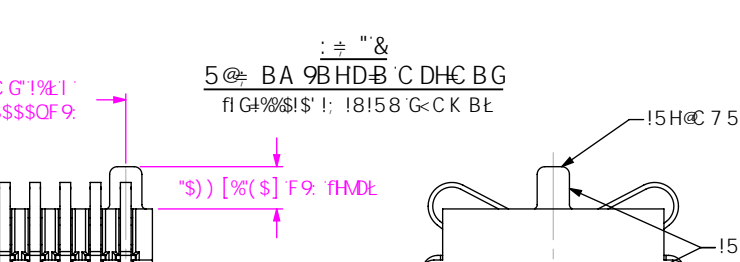
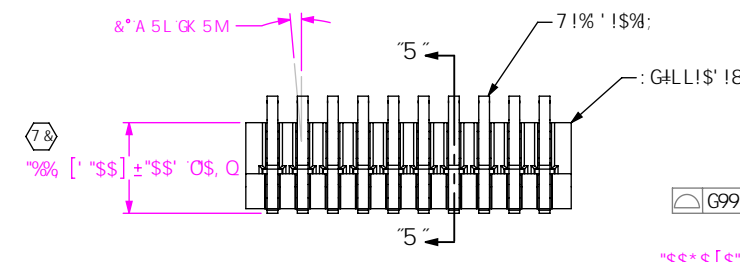
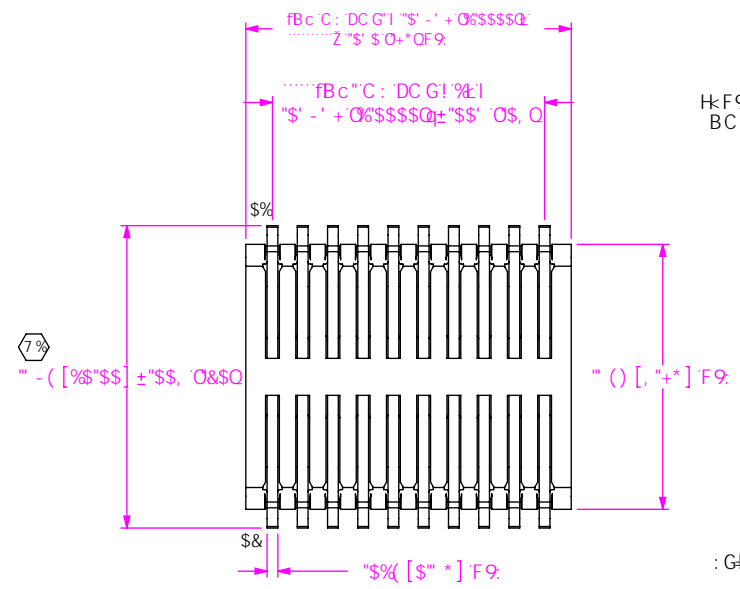

: G%LL!\$' !L!8!L!LL!LL

Bc C: DC G1 H C BG  
Hk F95 8 98 .1%SZ!&SZ1' SZ1(\$Z1)\$  
BC B!Hk F95 8 98 .1(\$) Hk F1 1)\$  
OB A I @H@GC: )O

6C 8M < 9< < H  
!\$' a a < 9< < H  
fl G9 7!%' !S%L<

D@HB;  
! : C @  
fl G9 7!%' !S%: t  
!< < 95 J M: C @  
fl G9 7!%' !S%< t

FC K GD97 = 7 5HC B  
!8: 8C I 6@  
fl G9: G%LL!\$' !8t

: = "%  
: G%LL!\$' !; !8' G< C K B

C DHC B G

!H: H5 D9/ F99@D5 7 25; B;  
f6@B?: C F H 698 D5 FH<  
!?: DC @M5 A 8 9: @A D5 8  
fl G9 7!)' \$S! '\$\$HfG99: = G( / ) z  
G< 99H' t  
!G8: G7 F9K 8 C K B C DHC B  
fl G9 Hk G( !(\$!) \* \$!LLf5 J 5 @6@  
C B %S%Z&S / ' \$ DC G' K Hk 15 8 C B @M  
G99 G< 99H( LfG99 BC H7) t

J

CDHC B 1 B 5 J 5 @6@K Hk  
5BMHk F95 8 98 B G F H C DHC B

5@ BA 9BHD B C DHC B

!5H' C D' G8 9 fl G9: G%LL!\$' !8!5HLt  
!56: 6C H C A G8 9 fl G9: G%LL!\$' !8!56!LL  
!58: 8! 5@fH C D/ '6C H C A L  
fl G9: G%LL!\$' !8!58!LZ'G99: = " &  
!@: @ 7? B; '7 @DfBC HHC C 98 5 Hk GHA 9L  
6@B?: C F B C 5@ BA 9BHD B"

Hk F95 8 98 B G F H C DHC B

!9: Hk F95 8 98 B G F H f9B; @G< t  
fl G9 B Q 7!&)' !1%SZ'G99: = " " ZG< H &  
!A: Hk F95 8 98 B G F H fA 9 F = t  
fl G9 B Q 7!A &!'S%Z'G99: = " " ZG< H &  
@95 J 9 6@B?: C F B C Hk F95 8 98 B G F H

1 B C H F 9 @5 G 9 8 : C F D F C 8 I 7 H C B

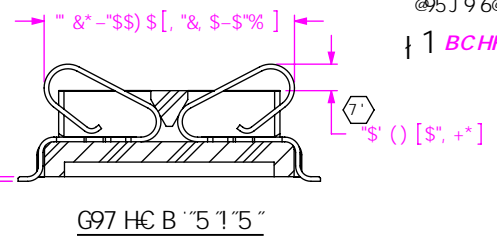
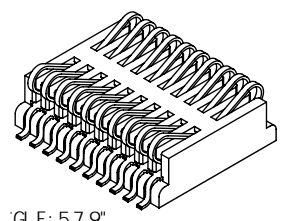
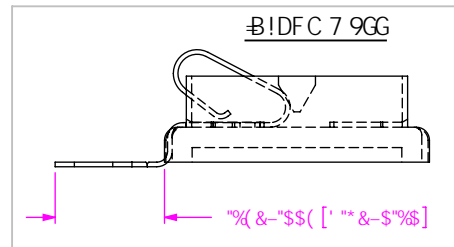

TABLE 1

No. OF POS.	MAX COPLANARITY
0-35	.004 [ .10]
40-50	.006 [ .15]

BCH9G  
% (Z) F9DF9G9BHG'5' 7 F #7 5 @8 A 9BGC B"  
&"A B A I A 'Dl G< C I H: C F 7 9. %& c n"  
" @ 5 8 B G9FHG B '8 F 97 HC B C: Hk 9 5 FFC K  
" I G B: < 5 B 8 @ 5 8 Hk 9 F A 5 @ B G9FH C B 'DF 9 G G"  
("Hk F95 8 98 B G9FH A I GH6 9 5 6 @9 HC < 5 B 8 @ & S' b) c n r j C:  
" HC FE I 9 A B K Hk C I H F C H 5 H B; 'C F " @ C G9 B B; " "  
)" Hk F95 8 98 B G9FH F 9 H B G C B 'H C '6 9 + V q' A B "  
\*" Hk F95 8 98 B G9FH H C '6 9: @ G< H C '\$S) G% Q6 9 @ C K < C I G B: 'G F: 5 7 9'  
J " ! G 8 C D H C B . F 9 H B H C B 'H C '6 9' V A B '5 B 8 A I G H K Hk G 5 B 8 " b) c n r j C: 'H C FE I 9'



I B @GG C Hk 9 F K @9 GD97 = 98 Z  
8 A 9 B G C B G 5 F 9 B B 7 < 9 G'  
H C @F 5 B 7 9 G 5 F 9:  
8 9 7 A 5 @ : @G  
" L L : '\$S) O & O : '&  
" L L L : '\$S) O % O  
" L L L L : '\$S&S O S) S O  
D F C D F 9 H 5 F M B C H P  
Hk G8 C 7 I A 9 8 H 7 C B H 6 B G B: C F A 5 H C B  
7 C B: @ 9 B H 5 @ 5 8 8 D F C D F @ 9 5 F M C  
G 5 A H 7 2 B 7 " 5 B 8 G 5 @ B C H 6 9 F 9 D F C 8 I 7 9 8  
C F H 5 B G 9 F 9 8 H C C Hk 9 F 8 C 7 I A 9 B H G C F  
8 4 7 @ 9 8 H C Hk 9 F C G F I 9 8 : C F 5 B M  
D I F D C 9 C Hk 9 F H 5 B H 5 H K < 7 < Hk 5 G  
C 6 5 8 9 8 K Hk C I Hk 9 9 L D F 9 G 9 8 K F H 9 8  
7 C B 9 8 H C: G 5 A H 7 2 B 7 "

A 5 H F @ 5 8 C " B C H G 7 5 @ 9 8 F 5 K B: G 9 9 H 7 5 @ 9 ( %  
B Q @ H C F . J 9 7 H 5 9 % S )  
7 C B H 5 7 H 6 Y 7 I  
B G 9 F H 6 F 5 G G

8 9 6 7 F D H C B:  
% a ' G B; @ 9 @ 9 A 9 B H B H F: 5 7 9

8 K: " B C "  
: G%LL!\$' !L!8!L!LL!LL

6 M 6 F 5 H 7 < 9 F % # & + # - : G< 9 9 H % C : (

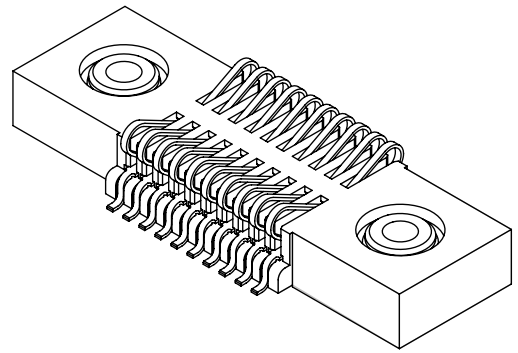
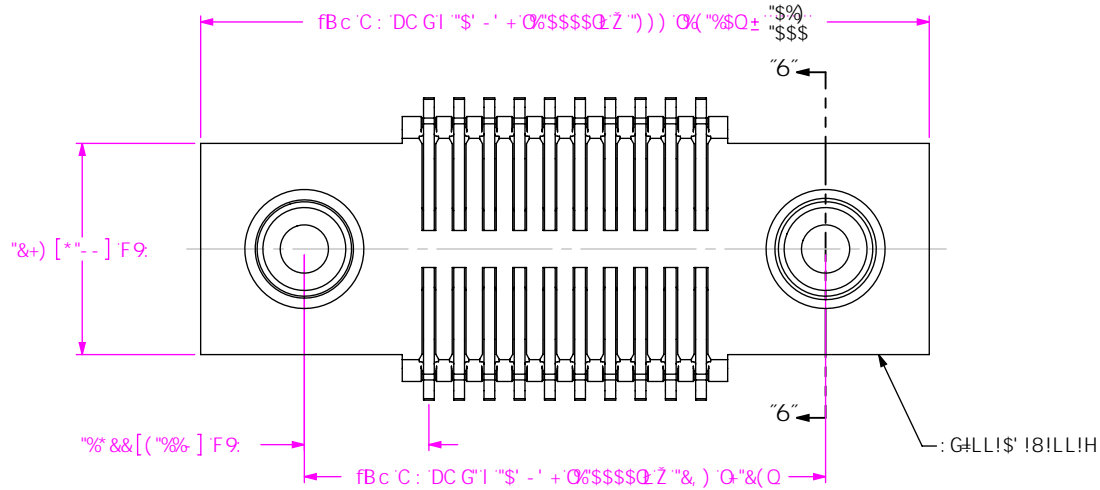

IA / !9. H F95898 'CDHC BG  
fG+%\$!\$' !: !8!A 'G-CCK BŁ  
fDĖ I 5HC BG5DD@MHC !%\$Z!&\$ / '!' \$ C B @M

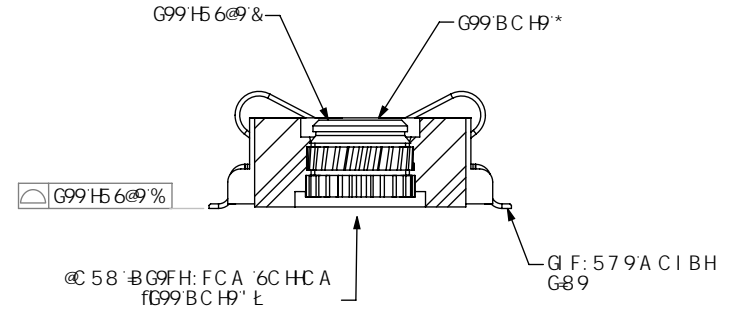
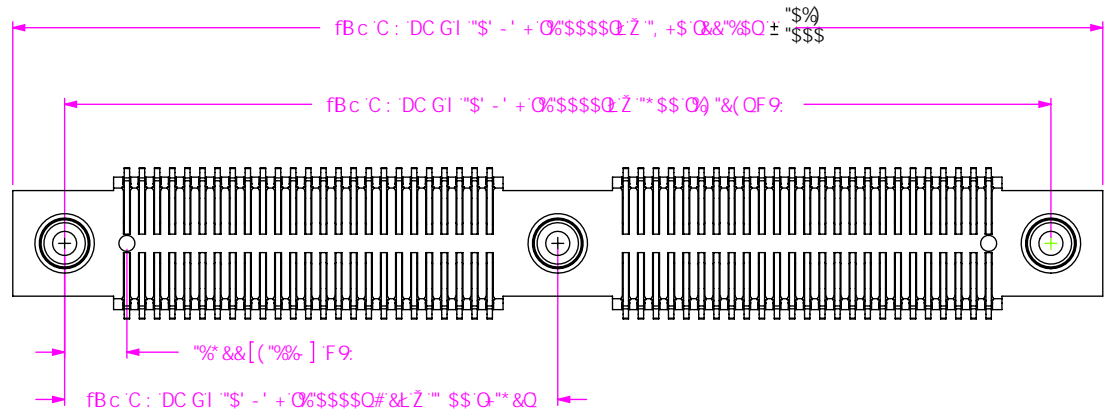

G97 H C B "6"1"6"

TABLE 2: INSERT OPTION

OPTION	INSERT	THREAD
-E	INS-C-2-56-100	2 x 56
-M	INS-C-M2-100-N	M2.0 x 4

D57 ? 5 ; B ; J 9K

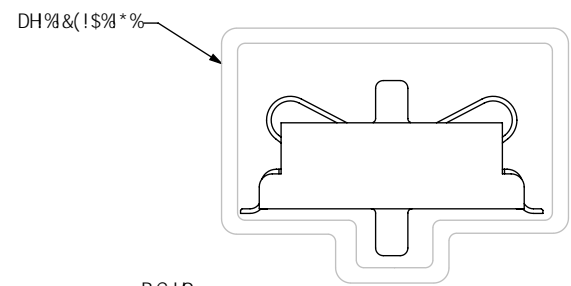

BC H P.

"D5FHG5F9HC '69D57?5: 98' B DH% & ( ! \$ % \* % H 69G  
"K #k 'H K C 'H I \$ ' D@ ; GD9F H 69"

DFC.DF.9H5.FMBC.H9  
H:GBC71A.98H7C.B15.BG.B.C.FA.5HC.B  
7.C.B: 8.98.H5.5.B8.D.F.C.F.9.H5.F.M.H.C.  
G.S.A.H7.2.8.7."5.B.8.G.5.M.H.C.H.6.F.9.F.0.F.C.81.7.98  
C.F.H.F.5.B.G.9.F.98.H.C.H.H.9F.8.C.71.A.98.H.C.F  
8.47.@.98.H.C.H.H.9F.G.C.F.I.98: C.F.5.B.M  
D.I.F.D.C.9.C.H.9F.H.5.B.H.5.H.K.<?<.H.K.5.G  
C.6.H.5.B.98.K.H.C.I.H.H.9.L.D.F.9.C.98.K.F.H.98  
7.C.B.98.H.C: G.S.A.H7.2.8.7."



89G7 F@HC B.  
%a a 'G-B; @9@9A 9B-H-BH9F: 579  
8K: "BC"  
: G-%L!\$' !L!8!L!L!L!  
6M 6F5H7 <9F %/#&+##- G<99H & C: (

: ≅ "(

!?. DC @MA 89: @A D58  
ft\$-, (Q) \$Q8-5 D58 I G98 C B 5@DC GHC BG  
9L 7 9DH! (\$/ !) \$ DC GHC BGK #k:  
Hk F95 8 98 B G9F HC DHC Bk

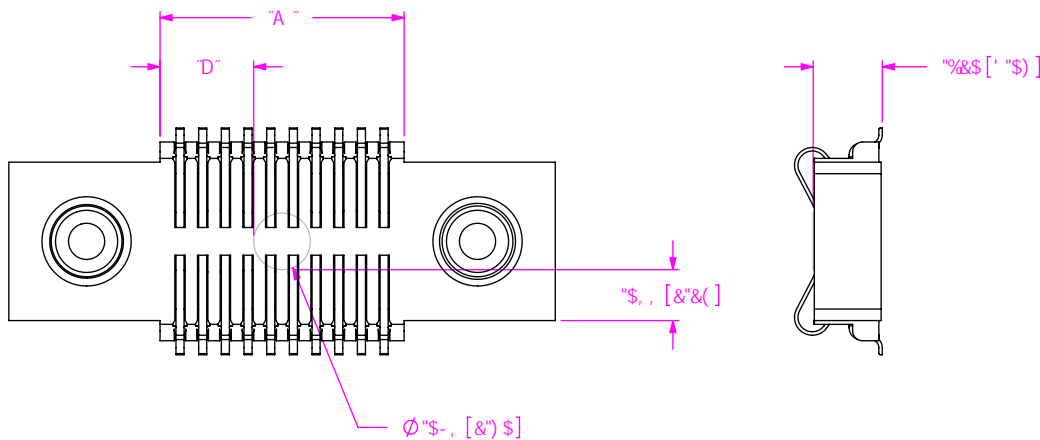

A "1 fBc C: DC GI "\$' - ' + @\$\$\$QZ "' \$O+\* OF9.  
D"1 dIA "!" \$-, (Q) \$Q# &q ± "\$&S0) %Q

: ≅ ")

!?. DC @MA 89: @A D58  
ft" %Q "O\$\$\$Q8-5 D58 I G98 C B @MC B  
I (\$/ !) \$ DC GHC BGK #k:  
Hk F95 8 98 B G9F HC DHC Bk

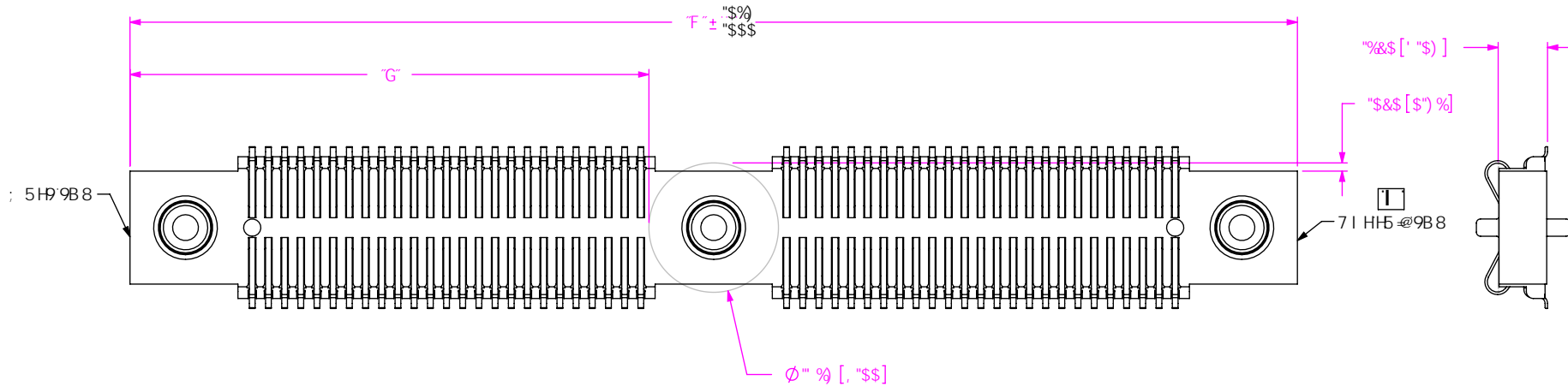

F"1 fBc C: DC GI "\$' - ' + @\$\$\$QZ "' \$Q&%"\$QF9.  
G"1 dIA "!" \$-, (Q) \$Q# &q ± "\$&S0) %Q

DFC DF-9H5 FMBC H9

H: 8C 71A 98H7C B16BG B- CFA 5HC B  
7 C B: 898H5 9588 DFC DF 945F HMC  
GSA H72 87 588 G-5H8C H69F90C 81 7 98  
CF HF5BG 9F98 HC CH: 9F 8C 71A 98HG CF  
8 47 @C 98 HC CH: 9F GCF I 98: CF 5BM  
DI FDC 09 CH: 9F H: 5B H: 5HK < 7 < #K 5G  
C 615 B 98 K #k C I H: 9 9L DF 9098 K F #H8  
7 C B 98HC: GSA H72 87 \*

8C BCH G7 5@ 8F5K B:

G: 99HG7 5@ 9. %



)&\$ D5F? 95GH6@ 8ZB 9K 5@5BM B' (+) \$  
D<C B 9.; %&L - ((!'+ .....SL.; %&L - (.) \$(+  
YIA UJ. )b z 4 G5A H7 Wc a ..... Wc XY.)' &&

89G7 F @HC B.

%a a 'GB; @ 9@9A 9BH-BHF: 57 9

8K: "BC"

: G%&LL!\$ !L!8!L!L!L!

6M 6F5H7 <9F %&#+#- -

G<99H""C: (

!G8.G7F9K 8CK B'CDHC B  
 fl G+%\$!\$' !: !8!58!G8 G<C K BL  
 fBJ 5-6@ B DC G!%\$Z!&\$ / '!' \$K #k !58'CDHC B'CB@M  
**CDHC B'1 B5J 5-6@K #k**  
**'5BM+k F95898 -BG9FHC DHC B**

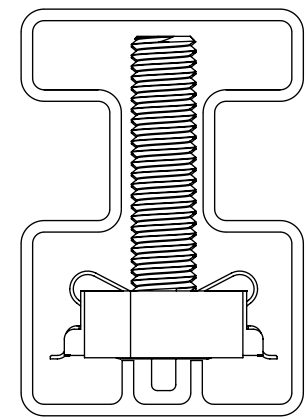
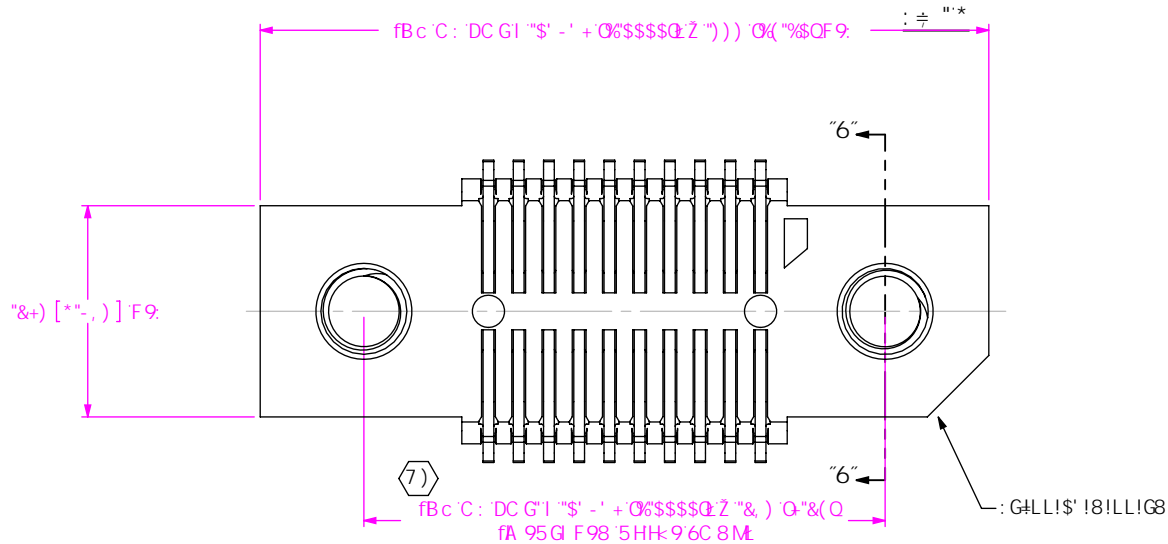

**J**  
 D57?5; B; J 9K

BCHP.  
 "D5FHG'5F9HC '69D57?5; 98' B'DH: G-\$%\$!' !G8  
 "'H 69GK #k HK C 'H!\$' 'D@ : GD9F'H 69"

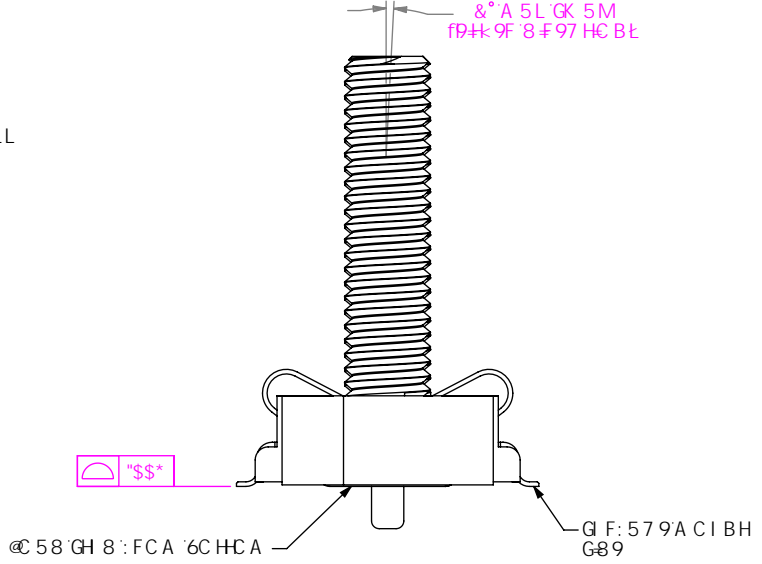
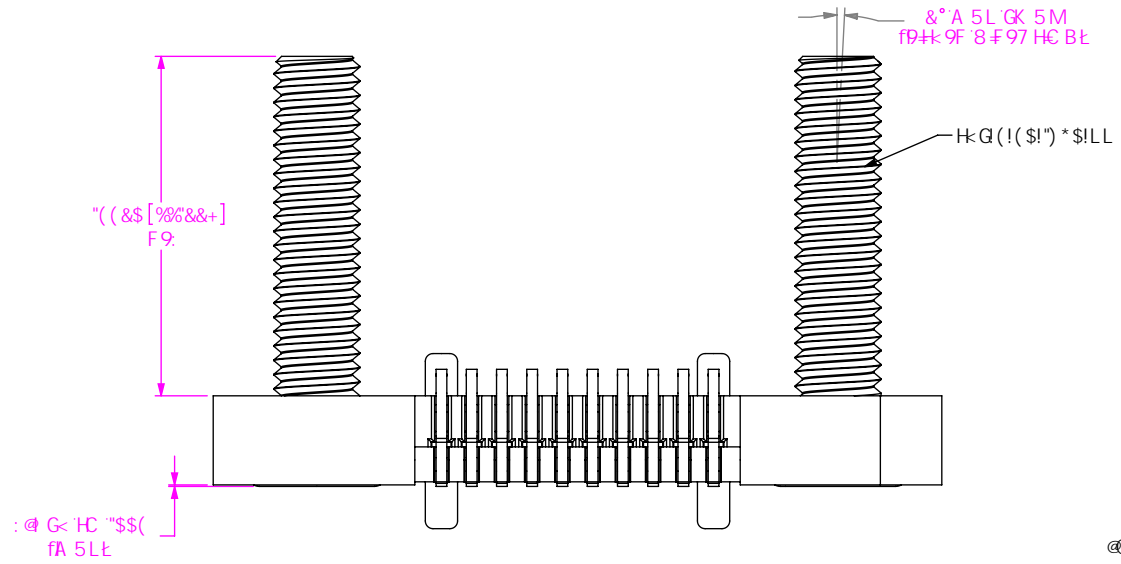

DFC.DF-915FMBCI9  
 H: 68C71A 98H7C B16BG B: CFA 5HC B  
 7CB: 898H59588 DFC DF 945FHM C  
 GSA H97 2 87 \*588 G-588CH H69F90FC 81 798  
 CF HF58G 9F98 HC CH: 9F 8C 71A 98HC F  
 847 @C98 HC CH: 9FGCF I 98: CF 58M  
 DI FDC @9 CH: 9F H: 5B H: 5HK <7 < #HK 5G  
 C 616 B98 K #k C I H: 99LDF 9098 K F #H8  
 7CB98HC: GSA H97 2 87 \*  
 8C 'BCHG7 5@9 8F5K B:  
 G: 99HG7 5@9 " %

**samtec**

)&\$ D5F? 95GH6@ 8ZB9K '5@5BM-B '(+% \$  
 D<C B9; %&L - ((! \* + ..... 5L; %&L - ( ) \$ (+  
 YIA UJ; )b z 4 GSA H97 'Wca ..... WEXY.)' &&

89G7 F@HC B.  
 %a a 'GB; @ 9@9A 9BH-BHF: 57 9  
 8K : "BC"  
 : G+%\$!\$' !L!8!L!LL!LL  
 6M 6F5H7 <9F %/#&+ #- - G<99H('C: (